

WSC Support System



Stainless steel masonry support systems play an important role in supporting the cladding to a structure and should be designed and installed with care. Wincro WSC Support Systems are normally fixed to steel and concrete frames, and have adjustment in all three planes by design.

RECOMMENDED BEST PRACTICE

It is recommended that a maximum initial lift of 5 courses of brickwork is built and tied to the structure. This lift should then be allowed to cure prior to further masonry being built in 1.2 metre lifts (in accordance with BS 5628-1:2005). This action will allow the first lift to form a rigid composite structure between the support angle, masonry structure and the wall ties ensuring any deflection and settlement is kept to the minimum.

STRUCTURAL FRAME

The structural frame should be checked for its line and level before the support system design is finalised and manufacture commences. If these are within the tolerances that the support system can accommodate, then the system can be manufactured and installed using the adjustments described below. If the structural frame is outside tolerance, please consult Wincro technical on 0114 242 2171 for advice.

SOFT HORIZONTAL JOINTS

It is essential that all soft horizontal joints have compressible filler underneath the support angle, with mastic seal on the exposed face of the cladding. A rebate in the brick (pistol brick) is normally required in order to conceal the joint. It is recommended that the horizontal leg of the angle is set 1.5-2.0mm above the top of the soft joint as this allows for normal vertical displacement under the masonry load.

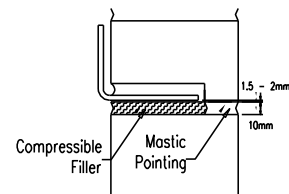

VERTICAL MOVEMENT JOINTS

Support system angles may span across vertical movement joints in brickwork, unless they coincide with a construction joint (movement joint in the structural frame). Systems must stop at construction joints.

VERTICAL ADJUSTMENT

The Patented Wincro serrated slot in the back of the bracket provides vertical adjustment of +/-26mm. It is important that all serrated washers must be installed in the correct orientation, to ensure the serrated teeth interlock as designed.

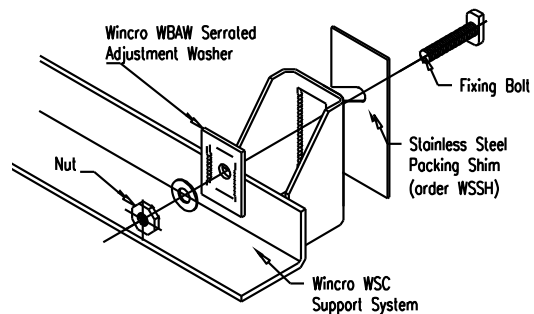

HORIZONTAL ADJUSTMENT

This form of continuous support system is designed with 10mm nominal gaps between individual angles. Horizontal cast-in channel, or horizontal slots in the steelwork (provided by others) facilitate adjustment of the angles.

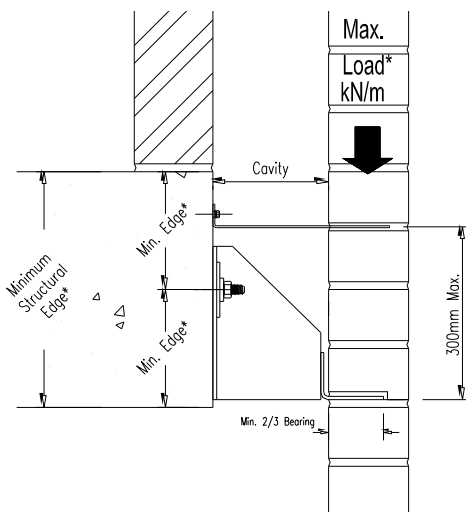

BEARING

Minor deviations in the position of the structural face can be catered for by adjusting the position of the masonry wall on the support angle. However, a minimum 2/3rds bearing must always be achieved. It is therefore recommended that angles be placed so the back edge of the masonry is within 10mm of the bracket.

WALL TIES

Stainless steel wall ties should be provided at a recommended maximum horizontal spacing of 450mm within 300mm above and below the support angle. These are essential to the correct working of the support system.

EDGE AND END DISTANCES

Edge and end distances will be detailed on Wincro General Arrangement (GA) drawings and it is important that the minimum edge and end distances are observed.



CAVITY WIDTH ADJUSTMENT

Minor deviations in the position of the structural face or the masonry wall can be made in two ways.

An increase in cavity is overcome by the use of full height stainless steel shims between the structural face and the back of the bracket. Individual shims should always be as thick as possible and the maximum allowable shim thickness is noted on Wincro GA drawings for each system. Normally, the maximum thickness of shims that should be used on one bracket is usually limited to the outside diameter of the fixing bolt or 16 mm, whichever is less.

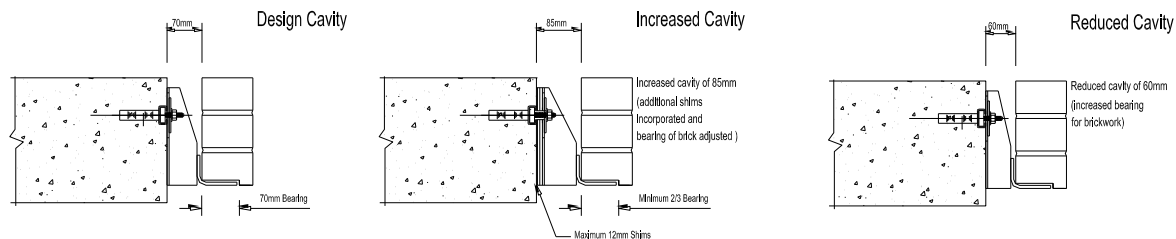

For larger widths, please contact Wincro technical on 0114 242 2171 for further advice on special shimming.

A reduction in cavity can be overcome by increasing the bearing of brick on the support angle. This may necessitate cutting the brick to clear the angle radius.

AVOIDANCE OF BI-METALLIC CORROSION

Bi-metallic (galvanic) corrosion can occur when stainless steel is fixed to carbon steel in a damp environment. Wincro recommend the use of Isolation Patches or the painting of the contact area between the metals to prevent such an occurrence.

FIXINGS

Wincro WSC can be fixed back to all types of structures. Only the components supplied with Wincro WSC support systems should be used for installation. Bolts should never be over tightened and it is important that all Wincro fixings are tightened to the specified tightening torques as noted on Wincro GA drawings. It is important that all serrated washers must be installed in the correct orientation, to ensure the serrated teeth interlock as designed.

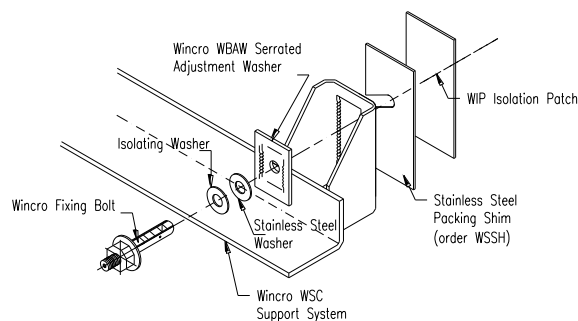

MATERIAL

Wincro WSC is manufactured from Grade 1.4301 Stainless Steel (304). For applications that may be subject to a more corrosive environment, a higher grade of material should be considered.

HEALTH AND SAFETY

The components of the WSC Support System are generally lightweight and easy to handle. However, they are produced from sheared plate and can have sharp edges. Suitable gloves/PPE should be worn by anyone handling and installing them.

GENERAL

All Wincro products are produced from Type 1.4301 (304) Stainless Steel u.n.o. and are generally produced from sheared plate. As with all similar industrial fabrications, these may present sharp edges and suitable personnel protective equipment should be worn at all times during handling and installation. In all cases, installation should be entrusted to appropriately qualified/experienced persons. All contact between dissimilar metals must be isolated using isolation patches/washers. All bolts specified must be installed and torqued to Manufacturers Recommendations / Guidelines. The Construction applications and details provided in this guide are indicative only.